



# **Communications Cable System & Infrastructure, Standards Design & Development**

For

# **Palomar College**

## **Table of Contents**

### **Inside Plant**

Recognized Standard Bodies

Topology description

Pathways and Spaces

Recognized Standard Bodies

Media            Fiber

                  Copper

Work Area Outlets

## General Requirements for All Telecommunications Rooms (MDF & IDF)

### Applicable Standards

Efforts have been made to harmonize the requirements and recommendations in this document with published telecommunications cabling standards. It is the responsibility of the designer to have a working knowledge of these standards and to actively use the standards, where applicable. The building cabling standards that have a direct bearing on this document include the following industry standards. It is also imperative that it is known that these standards will change as new technologies are introduced. Therefore it is required that all specified cable, fiber, and any other Telecomm installed products be reviewed by a certified BICSI RCDD, (Registered Communications Distribution Designer).

### Recognized Standard Bodies

#### Specification Title

ANSI/TIA/EIA-568-B.2-10 *Augmented Category 6 Standard*

ANSI/TIA/EIA-568-B.1 *Commercial Building Telecommunications Cabling Standard, Part 1: General Requirements.*

ANSI/TIA-568-C.1 *Commercial Building Telecommunications Cabling Standard.*

ANSI/TIA/EIA-569-B *Commercial Building Standard for Telecommunications Pathways and Spaces.* (In Canada, see specification CSA T530-1997.)

ANSI/TIA/EIA-570-B *Residential Telecommunications Cabling Standard.*

ANSI/TIA/EIA-606-A *Administration Standard for the Telecommunications Infrastructure of Commercial Buildings.* (In Canada, see specification CSA T528.)

ANSI/TIA/EIA-607-A *Commercial Building Grounding and Bonding Requirements for Telecommunications.* (In Canada, see specification CSA T527.)

ISO/IEC 11801 *Amendment 1 to 2<sup>nd</sup> Edition, Generic Cabling for Customer Premises.*

ANSI/TIA/EIA-862 *Building Automation Systems Cabling Standard for Commercial Buildings*

ANSI/TIA/EIA-942 *Telecommunications Infrastructure Standard for Data Centers.*

ASTM D 4566-05 *Standard Test Methods for Electrical Performance Properties of Insulations and Jackets for Telecommunications Wire and Cable, 2005*

BICSI Telecommunications Distribution Methods Manual (TDMM) 11th Edition

BICSI Information Transport Installation Manual (ITSM) 5th Edition

IEEE 802.3 *Standard for Information technology -Telecommunications and information exchange between systems - Local and metropolitan area networks – Specific requirements Part 3: Carrier Sense Multiple Access with Collision Detection (CSMA/CD) Access Method and Physical Layer Specifications*

IEC 61156-1 *Multicore and Symmetrical Pair/Quad Cables for Digital Communications – Part 1: Generic Specification, 2005*

NFPA-70 National Electrical Code 2008 edition

NECA/BICSI-568-A *Standard for Installing Commercial Building Telecommunications Cabling*

Federal Communications Commission Part 15 and Part 68

UL 444 – Standard for Safety of Communications Cable  
UL 1666 – Standard for Safety of Flame Propagation Height  
NFPA 262 – Flame Travel and Smoke of Wires and Cables  
Local Authority Having Jurisdiction

The portions of the above-referenced specifications that relate directly to the content of this document include:

Chapter 7 of ANSI/TIA/EIA-568-B;  
Chapter 7 of ANSI/TIA/EIA-569-B;  
Chapter 8 of ANSI/TIA/EIA-606-A;  
Chapter 7 of ANSI/TIA/EIA-607-A;  
Chapter 5 of ISO/IEC 11801.

### **Regulatory and Safety Standards**

Other standards that contain requirements pertaining to the safety of and access to private and public telecommunications networks include:

#### **Specification Title**

ANSI/NFPA 70 *The National Electrical Code*®, current edition.

CSA C22.1 *Canadian Electrical Code*®, Part 1.

FCC Part 68 *Code of Federal Regulations, Title 47, Telecommunications*.

UL 1459 *Underwriters Laboratories Standard for Safety—Telephone Equipment*.

UL 1863 *Underwriters Laboratories Standard for Safety—Communication Circuit Accessories*.

#### **References**

American National Standards Institute/Electronic Industries Alliance.

ANSI/EIA 310-D. *Racks, Panels, and Associated Equipment*.

Arlington, Va.: Electronic Industries Alliance, 1992.

American National Standards Institute/National Fire Protection Association, Inc.

ANSI/NFPA-70. *National Electrical Code*®.

Quincy, Mass.: National Fire Protection Association, Inc., 1999.

ANSI/NFPA-101. *Life Safety Code*.

Quincy, Mass.: National Fire Protection Association, Inc., 1991.

American National Standards Institute/Telecommunications Industry

Association/Electronic Industries Alliance.

ANSI/TIA/EIA-569-A. *Commercial Building Standard for Telecommunications Pathways and Spaces*.

Arlington, Va.: Telecommunications Industry Association/Electronic Industries Alliance, February 1998.

ANSI/TIA/EIA-607. *Commercial Building Grounding and Bonding Requirements for Telecommunications*.

Arlington, Va.: Telecommunications Industry Association/Electronic Industries Alliance, August 1994.

Canadian Standards Association.

CSA-C22.1. *Canadian Electrical Code*®, Part 1. Pointe Claire, Canada:

---

Revised 10/16/2009 for CAT6A AXi specifications

Canadian Standards Association, 1998.  
CSA-T527. *Grounding and Bonding for Telecommunications in Commercial Buildings*.  
Pointe Claire, Canada: Canadian Standards Association, 1994.  
CSA-T530. *Building Facilities, Design Guidelines for Telecommunications*.  
Pointe Claire, Canada: Canadian Standards Association, 1997.  
International Organization for Standardization/International Electrotechnical  
Commission. ISO/IEC 11801.  
*Information Technology—Generic Cabling for Customer Premises*.

Geneva: International Organization for  
Standardization/International Electrotechnical Commission, July 1995.  
National Fire Protection Association, Inc.  
*National Electrical Code® Handbook*, 7th ed. Quincy, Mass.:  
National Fire Protection Association, Inc., 1996.

### **U.S. National Electrical Code® (NEC®)**

For installations in the United States, the designer should be very familiar with the parts of the U.S. *NEC* listed below. For installations in Canada, the designer must know the corresponding sections of the *CEC*, also listed below. The relevant sections are:

- Article 800-52(b)—Communications Circuits. “Spread of Fire or Products of Combustion.” (In Canada, see *CEC* Sections 60-310 and 60-314.)
- Article 250 of Combustion.” (In Canada, see *CEC* Section 12-010.)
- Article 645—Information Technology Equipment. (In Canada, see *CEC* Section 60.)
- Article 770—Optical Fiber Cables and Raceways. (In Canada, see *CEC* Section 56.)
- Chapter 8—Communications Systems. (In Canada, see *CEC* Section 60.)

Additional sections of the *NEC* (or *CEC*) that the designer should become familiar with in order to develop appropriate equipment room designs are:

- Article 110—Requirements for Electrical Installations (including working spaces). (In Canada, see *CEC* Section 2.)
- Article 318—Cable Trays (including permitted uses, construction specifications, installation, and grounding). (In Canada, see *CEC* Section 12.)
- Chapter 2—Wiring and Protection (including services, feeders, and branch circuits). (In Canada, see *CEC* Sections 6, 8, 10, and 14.)
- Chapter 5—Special Occupancies (including hazardous locations and health care facilities). (In Canada, see *CEC* Sections 18 and 24.)
- Chapter 7—Special Conditions (including emergency and standby systems).

The NFPA also publishes the *NEC Handbook®*. This handbook includes the complete code along with figures, guidelines, and explanatory text that are helpful in understanding and applying the code. The Canadian Standards Association (CSA) publishes the *CEC Handbook®*, which contains similar explanatory text.

## **Pathways and Spaces**

### **Equipment Rooms (MDF)**

#### Definition

A Main Distribution Frame (MDF) is a special-purpose room that provides space and maintains a suitable operating environment for large communications and/or computer equipment. MDF rooms differ from Intermediate Distribution Frame (IDFs) in that MDFs are generally considered to serve a building or a campus, whereas IDFs serve a floor area of a building. Therefore, MDFs may be connected to backbone pathways that run both within and between buildings.

#### MDFs:

- Contain terminations, interconnections, and cross-connections for telecommunications distribution cables.
- Include work space for telecommunications personnel.
- Are built and laid out according to stringent requirements because of the nature, cost, size, and complexity of the equipment involved.

When designing MDFs, consider incorporating building information systems other than the traditional voice and data systems (e.g., community antenna television [CATV], fire alarm, security, audio, and other building signaling systems). In a campus system, each building may have an MDF. Although an MDF usually serves an entire building, many building designs use more than one MDF in order to provide one or more of the following:

- Separate facilities for different types of equipment and services
- Redundant facilities and disaster recovery strategies
- A separate facility for each tenant in a multi-tenant building

### **Multiple Functions**

In some cases, an MDF may also:

- Contain the entrance facility (for campus backbone, access providers [APs], or both).
- Serve as an IDF.

NOTE: Any or all of the functions of an IDF may be provided by an MDF.

### **Active Equipment**

The types of apparatus housed in MDFs vary greatly in size, purpose, and function—from power conditioning and backup systems, or environmental controls to telecommunications equipment for analog and digital networks. Typically, the telecommunications equipment serves the voice and data telecommunications needs of the building's occupants. Voice service on the customer's premises may be provided by one or more of the following systems:

- Central-office based service using direct lines, carrier equipment, or remote switching (for both voice and data)
- Private branch exchange (PBX) systems
- Small key telephone system (modern versions are fully functional PBXs)
- Adjuncts (voice mail, automatic call distribution, call accounting, etc.)

Data service on the customer's premises may be provided by one or more of the following systems:

- Centralized processing systems, such as mainframe and minicomputers using wide area networks (WANs), local area networks (LANs), and other proprietary terminal communications interfaces
- Personal computers, routers, and servers for LANs
- Modems for data over regulated and non-regulated telecommunications facilities
- Multiplexers for wideband data service (and aggregate voice and data) over telecommunications facilities. Other telecommunications services in the MDF may include those for power-limited services. Such services might include CATV, fire alarm, security, audio, and other building signaling systems.

### **Building Facilities**

Although building facilities (primarily safety and security, electrical, and heating, ventilating, and air conditioning [HVAC]) are necessary for the reliable and safe operation of telecommunications equipment, they are not typically the responsibility of the designer/engineer/consultant. They are, however, a critical factor in any MDF design. Therefore, the telecommunications system design must include specifications for such facilities in the MDF design.

The MDF (or IDF) must be dedicated solely to telecommunications and related facilities. Do not allow equipment that does not support the MDF (e.g., pipes, duct work, distribution of building power) to be located in or pass through the MDF.

### **Locating the Main Distribution Frame (MDF)**

The major factors that must be considered when choosing the location for an MDF are:

- Space required for the equipment.
- Provisions for future expansion.
- Access for delivery and installation of large equipment and cables.
- Building facilities that serve and are served by the MDF.
- AP requirements.
- Proximity to electrical service and mechanical equipment.
- Sources of electromagnetic interference (EMI).
- Relationship to service entrances for telecommunications and electrical power.
- Access and proximity to telecommunications cable pathways (including installations in which the MDF serves multiple backbones).
- If information is not available to compute the size of a terminal room, consider placing a storage room between the electrical room and the terminal room (MDF or IDF). In the future, if the terminal room needs to be enlarged, the storage room can then be modified, with little effort and cost.

### **Unacceptable Locations**

Do not locate MDFs in any place that may be subject to:

- Water infiltration/Steam infiltration.
- Humidity from nearby water or steam.
- Heat (e.g., direct sunlight).
- Any other corrosive atmospheric or adverse environmental conditions.

**NOTE:** Avoid locations that are below water level unless preventive measures against water infiltration are employed. The room must be free of plumbing and electrical utilities that are not directly required to support the telecommunications function. A floor drain is required if there is a risk of water entering the facility. Consider installing water alarms.

Shared use of MDF space with other building facilities must be avoided. Locations that are unsatisfactory for MDFs include space in or adjacent to:

- Mechanical rooms.
- Washrooms.
- Janitor's closets.
- Storage rooms.
- Loading docks.
- Any space that contains:
  - Sources of excessive EMI.
  - Hydraulic equipment and other heavy machinery that causes vibration.
  - Steam pipes.
  - Plumbing.
  - Clean-outs.

Avoid using the MDF as a means of accessing the spaces listed above and for additional restrictions on the use of MDFs for storage.

### **Access to Cable Pathways**

The MDF must have access to the backbone pathways.

Place the MDF at a location that minimizes the:

- Size and length of the backbone cables, especially in multiple-backbone situations.
- Length of horizontal cable (in situations where the MDF contains station jacks).

Examples of this type of location would include the:

- 10th floor of a 20-floor, single-tenant office building.
- Center of a large, single-floor building.
- Center of a large campus.

Layouts for cabling pathways are generally determined after the location of MDFs, and IDF's are established.

### **Delivery Access**

Locate the MDF so that it is accessible for the delivery of large equipment throughout its useful life. Consider the availability, size, and weight capacity of doors, hallways, elevators (or hoists), loading docks, and any other access routes to the MDF when choosing its location and designing its layout. Also consider any potential difficulties in scheduling the use of these routes and facilities for moving large equipment during installation or future.

## **Diverse Telecommunications Systems**

A properly designed telecommunications infrastructure (spaces, pathways, and cabling) is capable of supporting a broad range of telecommunications applications. For this reason, the ER should be capable of accommodating all the telecommunications services required by the building or campus. To provide this function, the designer should consider the diverse needs of these systems, so that the functions of all telecommunications systems that serve the same area may be combined into one space.

**NOTE:** Structured cabling allows diverse applications to be served by the same telecommunications cabling. In a structured cabling system, separate facilities are not required for voice and data systems. In cases where a computer room is provided as a separate facility, it should be adjacent to the MDF. This will help to simplify the installation of the large volume of cable required to link the two rooms.

## **Supporting Existing Systems**

In some cases, an MDF design must allow for the support or reuse of existing telecommunications equipment and/or cabling. Although the selection of an MDF location may be influenced by the location of existing telecommunications facilities, give careful consideration to the long-term benefits of a properly located and designed facility that is capable of meeting present and future needs. Weigh these benefits against the potentially short-term cost savings of adding to existing facilities that may restrict growth and lead to higher ongoing maintenance costs as telecommunications needs evolve.

## **Proximity to Electrical Service and EMI Sources**

When it is practical, minimize the length of the electrical power feeds from the electrical service entrance to the MDF. This ensures that other electrical circuits in the building will have a minimum effect on power quality. Linking these facilities will:

- Aid in designing an optimal grounding arrangement.
- Minimize grounding disturbances.

When planning an MDF location, be sure to consider potential sources of EMI. Locate the MDF far enough away from sources of EMI to reduce interference with the telecommunications cabling. Pay special attention to EMI from electrical power supply transformers, motors, generators, x-ray equipment, radio transmitters, radar transmitters, and induction heating devices. (For example, photocopying equipment should be located no closer than 3 m [10 ft] from the MDF.)

## **Space Allocation and Layout**

### **Introduction**

The layout of the major telecommunications equipment in an MDF must facilitate the routing of power and telecommunications cabling. The telecommunications distribution designer must carefully evaluate the location of each piece of equipment and the space allocated for it.

### **Providing Adequate Equipment Space**

An MDF must provide enough space for:

- All planned equipment.
- Access to the equipment for maintenance and administration.
- Growth.

The MDF must meet the space requirements specified by the equipment provider(s). If the MDF will contain equipment that serves different telecommunications applications (e.g., voice and data), each application's space and layout requirements must be taken into account. Manufacturers often provide suggested system and cabling layouts. The designer should consider all manufacturers' guidelines when designing the MDF layout. Even if the customer does not anticipate any growth, the MDF should include adequate space to support equipment changes with minimal disruption. Many equipment changes could take place during the life of any MDF.

In addition to space for telecommunications equipment and cabling, an MDF must include space for any environmental control equipment, power distribution/conditioners, and uninterruptible power supply (UPS) systems that will be installed.

### **Determining Size Based on Area Served**

When the designer does not know what specific equipment will be used in an MDF, the designer can use the amount of floor space that the room will serve to determine the minimum size of the MDF. To determine the minimum size of an MDF:

1. Divide the amount of usable floor space by 10 m<sup>2</sup> (100 ft<sup>2</sup>) to determine the number of individual work stations that the MDF will serve through both backbone and horizontal cabling. 10 m<sup>2</sup> (100 ft<sup>2</sup>) is an industry average used to calculate work stations. If work stations are smaller, the size of the MDF must be increased accordingly.

**NOTES:** Usable floor space includes the building area used by occupants in their normal daily work functions. For planning purposes, this should include hallways but not other common areas of the building. If the usable floor space is unknown, deduct 20 percent of the total floor area to estimate the usable floor space.

2. Divide the amount of total floor space by 23 m<sup>2</sup> (250 ft<sup>2</sup>) to determine the number of building automation system (BAS) devices that the MDF will serve through both backbone and horizontal cabling.

3. Multiply the number of work stations to be served by 0.07 m<sup>2</sup> (0.75 ft<sup>2</sup>) and the number of BAS devices to be served by 0.02 m<sup>2</sup> (0.25 ft<sup>2</sup>) to determine the MDF size. If there are fewer than 200 work stations, the MDF must be no less than 14 m<sup>2</sup> (150 ft<sup>2</sup>). For special-use buildings (e.g., hospitals, hotels), MDF size requirements may vary. Refer to ANSI/TIA/EIA-569-A (in Canada, CSA-T530-1999).

### **Arranging Equipment**

An MDF must have a layout that is easy to use and maintain. All aspects of the layout should be flexible enough for equipment to be changed without structural renovation. Planned growth in the areas served by the MDF should be considered in the initial design. Please refer to the Campus Communications Group for details of the interior layout.

### **Working Clearances**

For equipment installations in the United States, the *National Electrical Code*® (*NEC*®), provides requirements for working space and clearances around electrical equipment. *NEC* Section 110-26 generally requires a 0.91 m (3.0 ft) working clearance around equipment with exposed (e.g., unguarded, un-insulated) live parts; however, there are some exceptions that qualify equipment for smaller clearances.

Typical equipment cabinets require approximately 0.56 m<sup>2</sup> (6.0 ft<sup>2</sup>) of floor area and an additional 0.56 m<sup>2</sup> (6.0 ft<sup>2</sup>) of area for working clearance. Check the manufacturer's working clearance requirements when planning installations.

### **Access Provider (AP) Space Requirements**

If any equipment or cable terminations that are owned or maintained by an AP must be located in the MDF, determine the location and how much space is required. Include this space in the MDF design.

### **Cable Pathways within the Main Distribution Frame (MDF)**

The cable pathways described in this section are commonly used for routing bulk telecommunications cables within the MDF. Although they are also used for cable distribution between facilities, these pathways are particularly well suited for cable distribution within MDFs because of their capacity for handling bulk cables and their ability to accommodate change.

The cable pathways commonly used to route bulk cables within an MDF are:

- **Overhead cable trays**—Cable tray systems are commonly used for routing equipment and backbone cables between cross-connects equipment, and backbone pathways. Install trays overhead along the equipment rows, leading to the cross-connects. Coordinate tray locations with lighting, air-handling systems, and fire extinguishing systems so that fully loaded trays will not obstruct or impede their operation. In the United States, *NEC* Article 318 provides requirements for cable trays.
- **Access floor systems**—Access floors are commonly used to route equipment cables to cross-connects in large MDFs. Access floor systems (sometimes called “raised floors”) are often recommended by equipment manufacturers and are frequently used for telecommunications cabling when the MDF serves multiple applications (e.g., both computer and PBX equipment). In the United States, *NEC* Article 645 provides requirements for placing cable under access floors.

Give consideration to physical cable management in an access floor environment. High performance cabling (e.g., optical fiber, Cat 5e, and Cat6 twisted-pair) must be properly installed and managed to avoid transmission degradation. For this reason, the use of cable trays or other suitable means for cable management and protection under access flooring is strongly recommended.

• **Strapping, lashing, and hooking**—These methods involve a wide variety of small hardware for mounting and securing telecommunications cable to backboards, walls, ceilings, racks, and other fixed objects. These are usually low-cost methods that typically are not suitable as the primary means of cable distribution within MDFs because of their limited bulk cable capacity and their inability to accommodate change.

If MDF walls are needed for such cable routing, allocate suitable wall space and allow for growth. Cable routing systems that mount on walls, racks, or cabinets are useful for providing cable management between connecting hardware and the primary distribution pathways (e.g., overhead cable trays) within the MDF. Follow the manufacturers' instructions for cable routing to and from connecting hardware.

The following types of cable pathways are commonly used for telecommunications cables that enter and exit an MDF:

• **Slots and sleeves**—these are the most common methods for routing cable through building walls and floors. Circular sleeves are preferred because they are easier to firestop. A minimum of three 103 mm (4 trade size) sleeves shall be provided. If possible, slots and sleeves should be specified before the building is constructed because coring (cutting) holes through existing concrete:

- Is expensive.
- Can create dust or water damage.
- Can create structural hazards.

• **Conduits**—these are also a common method for routing cable through building walls and floors. Specify bushings at the conduit ends to avoid damage to cable sheaths. Although conduits may be used both within and between MDFs and IDFs, they generally are not recommended for cable distribution within MDFs and IDFs, unless required by code, (i.e. Building Automation Services, Fire Alarms etc.).

Palomar utilizes the ABF system in intrabuilding applications between terminal rooms (i.e. BDF to IDF). The following information includes, what would be considered a pathway issue for the campus fiber riser system.

### **Riser Tube Pathway Description**

Sumitomo's plenum rated, unjacketed FutureFLEX<sup>□</sup> tube cables are designed for use as an optical fiber cabling infrastructure in ABF applications that require an Optical Fiber Nonconductive Plenum (OFNP) fire rating. Plenum rated tube cables are UL 910 listed for plenum spaces. They are made from a black fluoropolymer that meets specific flame and smoke requirements. Plenum rated tube cables may also be used in indoor applications where: 1) lesser fire ratings such as Optical Fiber Nonconductive – General Purpose (OFN) or Optical Fiber Nonconductive – Riser (OFNR) apply or 2) no fire ratings apply. The individual tubes have a 6mm inside diameter and an 8mm outside diameter. These tube cables are pulled or placed in indoor routes for the purpose of individual tube interconnection to establish pathways for FutureFLEX<sup>□</sup> fiber bundle installation.

## **Electrical Power**

### **Power Requirements**

Most new telecommunications systems have strict electrical power requirements. To provide power and ensure smooth installation and good service after cutover, carefully follow:

- Equipment manufacturer's requirements and guidelines.
- Local electrical code requirements.

**NOTE:** In the United States, if there are no local code requirements; follow the latest edition of the *NEC*.

### **Coordinating with Other Electrical Facilities**

Although the designer/engineer/consultant is usually not responsible for designing or installing electrical power equipment, the designer must become familiar with it and be capable of specifying power service requirements for the MDF, based on present and projected customer needs. The designer should work closely with the people responsible for the electrical power systems, including power conditioning and backup power.

### **Maintaining Power Quality**

Telecommunications equipment is sensitive to power fluctuations. Because of this sensitivity, consider providing:

- Individual branch circuits.
- Dedicated power feeders.
- Power conditioning.
- Backup power.
- Dedicated telecommunications grounding and bonding.

If additional power conditioning, backup, or standby systems are required for the equipment, allocate space and allow for HVAC loading in the MDF for these systems.

### **Using Individual Branch Circuits**

An individual branch circuit serves a single load over dedicated phase, neutral, and grounding conductors from the feeder panel directly to a branch circuit receptacle (for cord-and-plug connected equipment), or equipment power terminal (for hardwired equipment).

The U.S. and Canadian definition of an "individual branch circuit" appears in *NEC* Article 100 and *CEC* Section 8.

**NOTE:** Sharing or "daisy-chaining" any individual branch circuit conductor's defeats the purpose, unless the design accommodates for multiple equipment from the same manufacturer (according to the manufacturer's recommendations).

## **Using Dedicated Power Feeders**

Provide MDFs with a power supply circuit that serves only the MDF and terminates in its own electrical panel. The feeders that supply the power for telecommunications equipment in MDFs should be dedicated only to supplying that equipment (in the United States, see *NEC* Article 215 and *CEC* Section 26). More than one dedicated feeder may be required for large installations with a wide variety of telecommunications equipment. Power required for other equipment in the room (e.g., fluorescent lighting, motors, air conditioning equipment) should be supplied by a separate feeder, conduit, and distribution panel.

Using dedicated circuits:

- Provides for individual system maintenance.
- Minimizes electrical interference between systems. Separate feeders reduce the chance that electrical noise and impulses generated by the other loads will degrade the performance of the telecommunications equipment. Although their initial installation cost is higher, separate feeders greatly enhance equipment operation and maintenance.

## **Environmental Control (HVAC)**

### **Introduction**

Telecommunications equipment can be sensitive to environmental conditions and typically has strict requirements for its operating environment. Therefore, an MDF must have either:

- Dedicated HVAC equipment, or
- Access to the main HVAC delivery system.

In addition to temperature control, the environmental requirements for telecommunications equipment may include:

- Humidity control.
- Dust and contaminant control.

Environmental requirements for equipment vary from manufacturer to manufacturer. Follow the manufacturer's requirements exactly to ensure reliable operation and to keep warranties valid.

### **HVAC Operation**

Telecommunications equipment usually requires the HVAC system to function properly at all times (24 hours per day, 365 days per year). If a building's HVAC system cannot ensure continuous operation (including weekends and holidays), provide a stand-alone HVAC unit with independent controls for the MDF. It is required that the HVAC system in all MDF/IDF rooms must be separate from the building central HVAC system. If an emergency power source is available in the building, connect the HVAC system that serves the MDF to it. The HVAC system that serves the MDF should be tuned to maintain a positive air pressure differential with respect to surrounding areas. If environmental conditions warrant, provide equipment to control humidity and air quality. Consider that the following equipment may be located inside the MDF and could affect HVAC sizing requirements:

- Environmental control equipment
- Power distribution/conditioners
- UPS systems with a rating of 100 kVA or lower

## **Environmental Control Requirements**

The designer must consider the HVAC requirements of each piece of equipment that will be placed in the MDF. The final MDF design must accommodate any special or specific requirements. However, typical equipment requirements can be used as general guidelines until specific equipment requirements are known. The environmental control systems for the MDF should be able to meet the standards shown in the table below.

### **Environmental control systems standards for MDFs and IDFs**

#### **Environmental Factor Requirement**

Temperature 18 °C to 24 °C (64 °F to 75 °F)

Relative humidity 30% to 55%

Heat dissipation 750 to 5,000 Btu per hour per cabinet

**NOTES:** Filtration systems may be required to minimize particle levels in the air.

Keep changes in temperature and humidity to a minimum.

HVAC sensors and controls must be located in the MDF. Ideally, the sensors are placed 1.5 m (5 ft) above the finished floor.

## **IDF INFORMATION**

### **Introduction**

A properly designed IDF includes a (MDF) that provides a floor-serving distribution facility for horizontal cabling. This cross-connect is capable of providing horizontal cable connections to floor-serving telecommunications equipment and backbone cables from:

- Other IDFs.
- Equipment rooms.
- Entrance facilities.

The IDF should be provided separate IDFs to serve the structured cabling needs of all building.

In some cases, it may be necessary to combine the building and floor-serving functions of the MDF and IDF in one room. Instances where the two may be combined include smaller buildings (less than 500 m<sup>2</sup> [5000 ft<sup>2</sup>]) and those with limited space for distribution facilities.

### **Floor Space Served**

There must be at least one IDF per floor. Multiple rooms are required if the:

- Usable floor space to be served exceeds 1000 m<sup>2</sup> (10,000 ft<sup>2</sup>), or
- The cable length between the IDF and the telecommunications outlet, including slack, exceeds 90 m (295 ft).

## Size Requirements

Size requirements are based on distributing telecommunications service to one individual work station per 10 m<sup>2</sup> (100 ft<sup>2</sup>) of usable floor space. Minimum IDF sizes are shown in the following table.

### If the Serving Area Is...

500 m<sup>2</sup> (5000 ft<sup>2</sup>) or less

Larger than 500 m<sup>2</sup> and less than or equal to 800 m<sup>2</sup> (>5000 ft<sup>2</sup> to 8000 ft<sup>2</sup>)

Larger than 800 m<sup>2</sup> and less than or equal to 1000 m<sup>2</sup> (>8000 ft<sup>2</sup> to 10,000 ft<sup>2</sup>)

### Then the Interior Dimensions of The Room Must Be at Least...

3.0 m x 2.4 m (10 ft x 8 ft).

(See note below.)

3.0 m x 2.7 m (10 ft x 9 ft).

3.0 m x 3.4 m (10 ft x 11 ft).

NOTE: ANSI/TIA/EIA-569-A recommends a minimum IDF size of 3.0 m x 2.1 m (10 ft x 7 ft). The size of 3 m x 2.4 m (10 ft x 8 ft) is specified here to allow a center rack configuration.

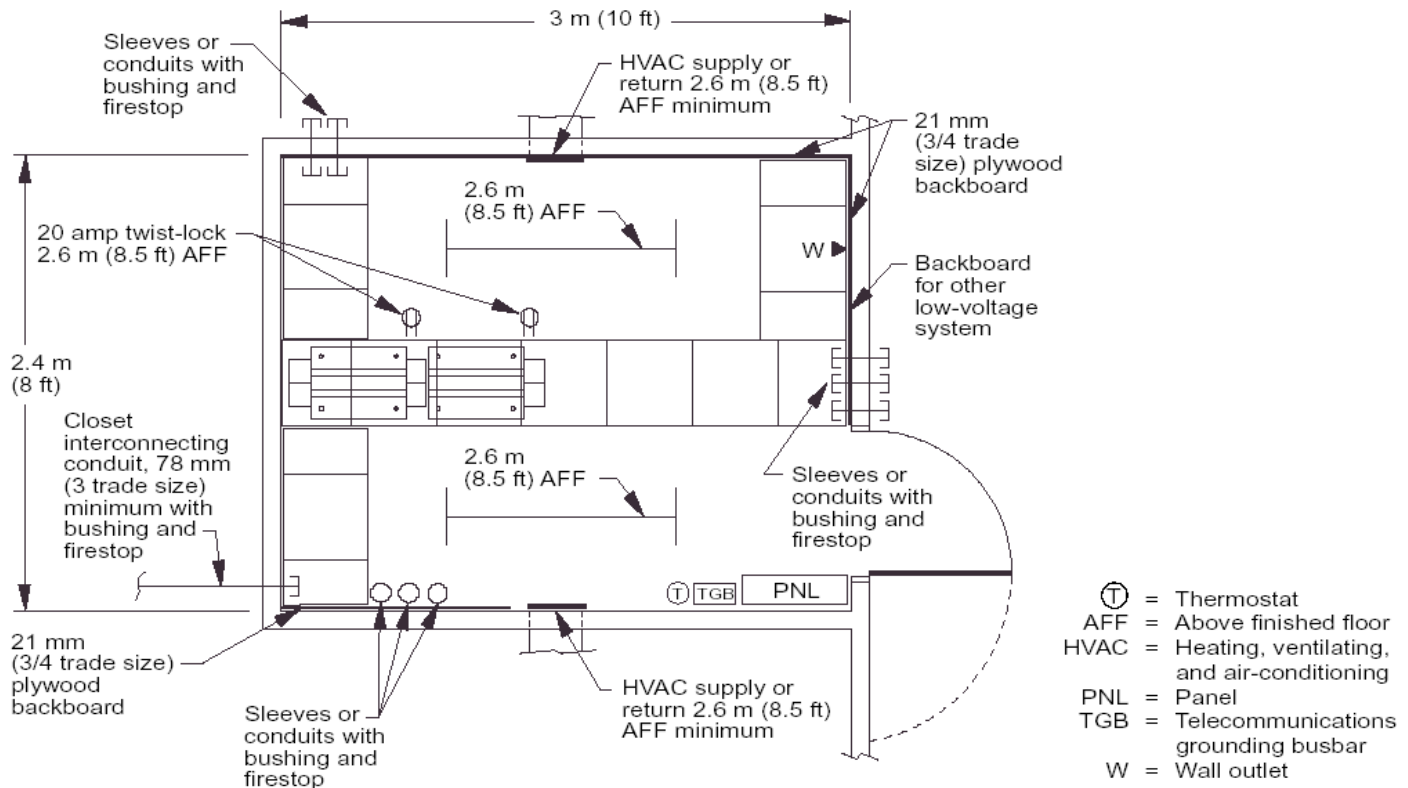

### **Smaller Buildings**

In smaller buildings, less space is required to serve the telecommunications distribution needs of the occupants.

#### **If the Building Is Smaller Than...**

500 m<sup>2</sup> (5000 ft<sup>2</sup>)

100 m<sup>2</sup> (1000 ft<sup>2</sup>)

#### **It May Be Served By...**

Shallow closets

Wall cabinets.

Self-contained cabinets.

Enclosed cabinets.

### **Smaller Building Size Requirements**

For buildings where the usable floor space served is less than 500 m<sup>2</sup> (5000 ft<sup>2</sup>), interior dimensions of:

- Walk-in closets must be at least 1.2 m x 1.8 m (4 ft x 6 ft).
- Shallow closets must be at least 0.6 m deep x 2.6 m wide (2 ft deep x 8.5 ft wide).

NOTES: Installation of active equipment in shallow or walk-in closets is not recommended because many types of equipment require environmental control and a depth of at least 750 mm (30 in). All utility cabinets must be listed and marked in accordance with applicable electrical codes.

### **Layout Considerations**

When designing the layout of a IDF, consider the following.

#### **If...**

A substantial portion of the IDF is dedicated to backbone cable distribution

Special telecommunications services are provided facilities

More than one tenant is served from the same IDF

#### **Then...**

Include space for splicing and ladder racking.

Allow additional space for cross-connect and (possibly) active equipment.

Provide clear separation and identification of each tenant's equipment and terminations.

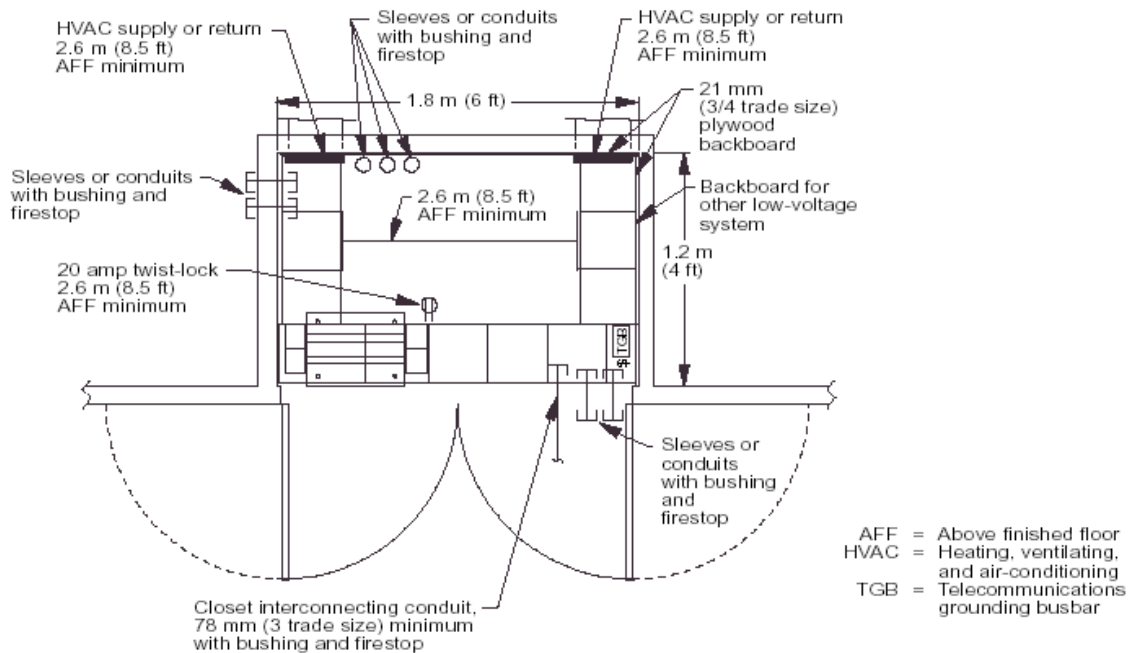

### Clearances

Provide the following clearances for equipment and cross-connect fields in the IDF:

- Allow a minimum of 1 m (3 ft) of clear working space from equipment and cross-connect fields.
- Allow for 150 mm (6 in) depth off wall for wall-mounted equipment.
- Provide space of at least 1.2 m (4 ft) from center line of rack to wall in the front and in the rear of each equipment rack or cabinet. Provide aisles at least 810 mm (32 in) wide.

**NOTE:** Specify equipment racks and cabinets that meet ANSI/EIA 310-D.

- In corners, a minimum side clearance of 300 mm (12 in) is recommended.

Consult manufacturer's documentation and local codes for specific requirements.

**NOTE:** In many cases, equipment and connecting hardware may extend beyond racks and backboards. It is important to note that the clearance is measured from the outermost surface of these devices, rather than from the mounting surface of the rack or backboard.

### Special Size Considerations

For existing installations and building retrofits, it is recognized that the preceding IDF size requirements may not be possible in all cases. If, for reasons beyond the control of the designer/engineer/consultant, the minimum size requirements cannot be met, provide

1.2 m (4 ft) depth x 1.8 m (6 ft) width x 2.6 m (8.5 ft) height (inside dimensions) of IDF space with sliding or double 900 mm (36 in) doors for every 240 terminations served.  
NOTE: The minimum dimensions provided above may not be adequate if special communications services (CATV, security, alarm, etc.), building automation functions, or provisions for future growth are needed.

### **Ceiling Height**

The minimum ceiling height is 2.6 m (8.5 ft) above the finished floor.  
When a ceiling distribution system is used, design IDFs with adequate pathways or openings through beams and other obstructions into the accessible ceiling space.  
To permit maximum flexibility and accessibility of cabling pathways, false ceilings are not permitted in IDFs.

### **Bonding and Grounding**

In addition to the general grounding requirements listed in the requirements section, the following requirements shall apply:

- If multiple equipment grounding or intersystem grounding is necessary, a copper ground bar shall be provided.
- If backbone cable is furnished by an SP, they must be consulted to determine any special grounding requirements that may apply.

### **Conduits, Trays, Slots, Sleeves, and Ducts**

- Locate slot/sleeve systems in places where pulling and termination will be easy
- Where vertical and horizontal offsets are required, consider bend radius requirements and service loop issues.
- Sleeves and slots shall not be left open after cable installation. Firestop all sleeves and slots in accordance with applicable building codes.
- The size and number of conduits or sleeves used for backbone pathways depends on the usable floor space served by the backbone system. However, at least three 103 mm (4 trade size) sleeves are recommended.
- Interconnect multiple IDFs on a floor with a minimum of one 78 mm (3 trade size) conduit or a pathway that provides equivalent capacity.

### **Doors**

Design IDFs to have fully opening (to 180 degrees recommended), lockable doors that are at least 0.91 m (3.0 ft) wide and 2.0 m (6.7 ft [80 in]) tall.

**NOTE:** Door sills are not allowed because they impede the movement of equipment. Center posts are permitted, if required. Install doors to either slide side-to-side or be removable. Doors that open outward provide additional usable space and reduce constraints on IDF layout but are sometimes prohibited by commercial building codes.

### **Dust and Static Electricity**

Avoid dust and static electricity by:

- Installing tile instead of carpet.
- Treating floors, walls, and ceiling to minimize dust.

NOTE: Consult the building contractor for recommendations on preferred treatments, paints, or other coatings that may be applied to minimize dust and static electricity.

### **Environmental Control**

Provide HVAC that will:

- Maintain continuous and dedicated environmental control (24 hours per day, 365 days per year). If emergency power is available, consider connecting it to the HVAC system that serves the IDF.
- Maintain positive pressure with a minimum of one air change per hour in the IDF.
- Dissipate the heat generated by active devices.
- Satisfy applicable building codes.
- Maintain a temperature in the following ranges:

### **For Telecommunications Rooms That... The Temperature Range Should Be...**

|   |                                  |
|---|----------------------------------|
| Do not contain active equipment                           | 10 °C to 35 °C (50 °F to 95 °F). |
| It is preferable that temperature be maintained to within | ± 5 °C (± 9 °F)                  |
| of the adjoining office space                             |                                  |
| and that humidity be kept below                           | 85% relative humidity.           |
| House active equipment                                    | 18 °C to 24 °C (64 °F to 75 °F). |
| The humidity range should be                              | 30% to 55% relative humidity.    |

### **Fire Protection**

- Provide fire protection for the IDF, if required by applicable codes.
- If sprinkler heads are provided, install wire cages to prevent accidental operation.
- For wet pipe systems, drainage troughs are recommended to protect equipment from any leakage that may occur.
- To prevent water damage, consider using “dry pipe” sprinkler systems.

### **Flood Prevention**

Locate IDFs above any threat of flooding. Avoid locations that are below or adjacent to areas of potential water hazard (e.g., restrooms and kitchens).

### **Floor Loading**

ANSI/TIA/EIA-569-A specifies a minimum floor loading of 2.4 kPa (50 lbf/ft<sup>2</sup>). However, the designer shall determine what floor loading will be needed for the equipment. The designer shall check with the building architect for actual floor loading rating. If rated floor loading is less than the actual determined requirement, the designer shall obtain the services of a licensed structural engineer.

### **Grounding**

- All equipment and cable shields must be properly grounded.

## **Lighting**

- Provide a minimum equivalent of 500 lux (50 footcandles) measured 1 m (3 ft) above the finished floor.
- Do not use dimmer switches.
- Coordinate closely with the rack placements.
- Locate light fixtures a minimum of 2.6 m (8.5 ft) above the finished floor.
- Use light-colored paint to enhance room lighting.
- Emergency lighting is recommended. Place emergency lighting to ensure that the loss of power to normal lights will not hamper an emergency exit from the IDF.
- Power for lighting should not come from the power panel inside the IDF. At least one light should be on normal power, and one light should be on emergency power, if available.

## **Location**

- To minimize the horizontal cable lengths (with a maximum of 90 m [295 ft]), locate the IDF as close as possible to the center of, and on the same floor as the area it is intended to serve.
- IDF location may also be limited by the maximum cabling distances possible installed to the various end user equipment.
- Ensure that IDFs are accessible from a hallway or other common area. IDFs that serve multiple tenants must be accessible from a public hallway or other common area that serves the same tenants as the IDF.
- IDFs in multi-floor buildings should be stacked vertically.

## **Other Uses**

IDFs must be dedicated to the telecommunications function and related support facilities.

- Equipment not related to the support of the IDFs such as piping, duct work, and distribution of building power must not be located in, or pass through, the IDF.
- The IDF may not be shared with building or custodial services that may interfere with the telecommunications systems. For example, sloop sinks and cleaning materials such as mops, buckets, or solvents must not be located or stored in the IDF.

## **Power**

- IDFs must be equipped to provide adequate electrical power. U.S. requirements are as follows:
  - Branch circuits for equipment power that are protected and wired for 20A capacity.
  - A minimum of (1) 208 vac dedicated circuit, plug type, TBD, (Contact Palomar IT Group for plug style).
  - A minimum of two dedicated non-switched 3-wire 120 volt (V) alternating current (ac) duplex electrical outlets for equipment power, each on separate branch circuits.
  - Separate duplex 120 V ac convenience outlets (for tools, test sets, etc.), which are:
    - Located at least 150 mm (6 in) above the finished floor. (Outlet heights of less than 375 mm [15 in] are allowed because the IDF is not considered a public space.)
    - Placed at 1.8 m (6 ft) intervals around perimeter walls.
    - Coordinate light switch locations for easy access upon entry.

- All outlets must be on non-switched circuits (outlet power must not be controlled by a wall switch or other device that may lead to inadvertent loss of service).
- Convenience outlets should be identified and marked.
- Additional outlets or power strips may be required, depending on the amount and type of equipment planned for the IDF.
- Consider providing emergency power to the IDF with automatic switchover capability.
- In many cases, it is best to install a dedicated power panel to serve the IDF.
- Distribution panels that serve telecommunications equipment should be separate from those that serve lighting fixtures.
- At least one outlet should be on normal power, and one outlet should be on emergency power, if available.

### **Security**

- Keep IDFs locked.
  - Assign IDF keys to building personnel who remain on site throughout their shift.
- The building owner or agent should control access to IDFs that serve multiple tenants. When multiple personnel or tenants require routine access, consider installing security systems that track when telecommunications facilities are accessed and by whom.

### **Wall Linings**

If equipment racks are not provided, at least one IDF wall should be lined with AC-grade or better plywood, 2.4 m (8 ft) high with a minimum thickness of 19 mm (0.75 in). Securely fasten the plywood to wall-framing members to ensure that it can support attached equipment.

**NOTES:** Plywood should be void-free and either fire-rated or treated on all sides with at least two coats of fire-resistant paint. Alternately, the plywood may be covered with sheet rock to satisfy building code requirements in some areas.

When shallow distribution cabinets are used, they must meet the appropriate requirements from safety listing. Mount plywood to cover the entire area on which connecting hardware and cable management hardware may be mounted, including sides (desired). Use flush hardware and supports to mount plywood. Ensure that the strength and placement of the hardware are sufficient to handle the total anticipated load (static and dynamic) and mounting of cabling components.

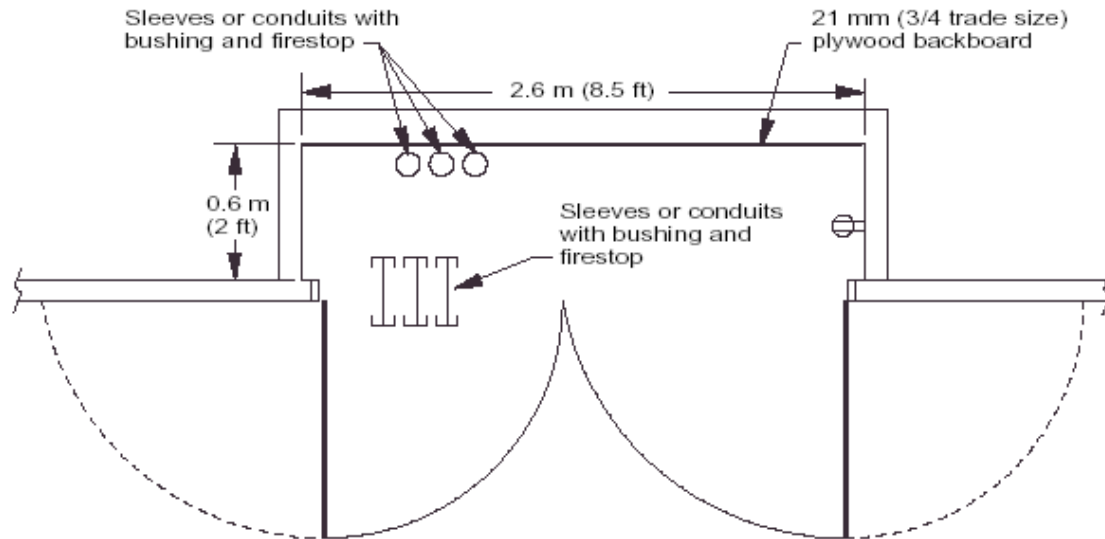

## Wall and Rack Space for Terminations

Whenever possible, locate space for terminations of each type of cable on one continuous wall or rack. Plan for:

- A clear space of 125 mm–150 mm (5 in–6 in) above and below the top and bottom of the connecting hardware for cable handling.
- Additional rack or backboard space for routing cables, patch cords, and/or cross-connect jumpers (cables may also be routed behind the connecting hardware in some cases).

NOTE: Corners result in 300 mm (12 in) of lost space on each wall and make ring runs necessary. In addition to lost space, mounting connecting hardware and equipment close to corners adds to the difficulty of installation and servicing. Reserve narrow side walls for:

- Splice cases.
- Miscellaneous items.
- Cross-connect fields, patch panels, and active equipment in the IDF must be placed to allow cross connections and interconnections via jumpers, patch cords, and equipment cables whose lengths per channel do not exceed:
  - 10 m (33 ft) total, for patch cords/jumpers, equipment cables connected to the work station cord.
  - 20 m (66 ft) for patch cords or jumpers located in the BDF/IDF.

IDFs are generally considered to be floor-serving (as opposed to building- or campus-serving) spaces that provide a connection point between backbone and horizontal distribution pathways. IDF design should consider incorporation of other building information systems in addition to traditional voice and data needs, such as community antenna television (CATV), alarms, security, audio, and other building signaling systems. IDFs provide an environmentally suitable and secure area for installing:

- Cables.
- Cross-connects.
- Rack- and wall-mounted hardware.
- Telecommunications equipment.

The design of IDFs depends on the:

- Size of the building.
- Floor space served.
- Occupant needs.
- Telecommunications service used.
- Future requirements.

A dedicated telecommunications distribution facility is necessary because of increased demand for:

- Desktop automation.
- Voice and data integration.
- Desk-to-desk information exchange.
- Integration of the other building systems into the structured cabling system.

TIA standards specify a structured telecommunications infrastructure that distributes telecommunications services to each individual work stations.

Central to this function is the IDF that allows, in a structured way, the interconnection of work stations on the same floor or to other floors via the backbone facility.

## Palomar Standard MDF/IDF Rack Design

Standard Rack Design for MDF/IDF Rooms



- Top of the rack – the Fiber Termination Unit, (FTU)
- Below the FTU, typically the first patch panel will be the Analog phone system, patch panel type depending upon type of cable entering building. 24 port – 25 pair or 48 port – 50 pair.
- 48 port angled 10G rated patch panels with NO horizontal wire management. The patch panels will be labeled A-Z starting from the top panel. Example A1-48, B1-48, C1-48
- Wire Management – The use of vertical wire management system is used on all racks in the district. CPI Swing Gate type rack is preferred. No horizontal wire management.
- Switching equipment – core switch or 24 or 48 port switches depending upon the building overall data drops. Installation of equipment done by district Information Services staff.
- In a non-central UPS supported building – The installation of a rack mount UPS will be installed below all equipment in this rack design.
- The rack shall be mounted to meet the current Seismic regulations and codes.

## **Horizontal Pathway Systems**

### **Introduction**

Horizontal pathway systems consist of structures that conceal, protect, support, and provide access to horizontal cables between the:

- Telecommunications outlet/connector used to connect work area equipment (voice, data, and video) at the work area, and in the serving Telecommunications terminal room (MDF/BDF/IDF).

Pathway implementation involves both the pathway for containment of cable as well as related spaces, such as pull boxes and splice boxes, which aid in the installation and change of cable. When designing a building, the layout and capacity of the horizontal pathway system must be thoroughly documented in floor plans and other building specifications. The designer is responsible for ensuring that these systems have built-in flexibility to accommodate tenant movement and expansion. In addition, the horizontal pathway system should be designed to make maintenance and relocation of cabling as easy as possible.

### **Reference areas of Standards**

#### **ISO/IEC 11801:2002**

NOTE: All design and construction for pathway systems must meet or exceed national and local codes and standards.

### **Design Considerations**

Select and design the type and layout of the horizontal pathway system carefully. After a building is constructed, it may be more difficult to gain access to horizontal cabling than backbone cabling. Therefore, the skill, effort, and time required to make horizontal cabling changes can be very high.

When selecting and designing the horizontal pathway system, it is important to consider the design's ability to:

- Accommodate cabling changes.
- Minimize occupant disruption when horizontal pathways are accessed.

In addition to providing for current occupant needs, the horizontal pathway system design must:

- Facilitate on-going maintenance of horizontal cabling.
- Accommodate future additions to and changes in cabling, equipment, and services.

The pathway design should allow for a minimum of three cable runs per individual work areas. Although only two cables per work area are required, the additional pathway capacity is needed to facilitate future additions and changes as the user's needs evolve.

### **Avoiding Electromagnetic Interference (EMI)**

Avoiding EMI is an important consideration in the design of cable pathways. Providing separation distance from sources of EMI for these elements of the telecommunications infrastructure inherently provides separation of their contents (e.g., the cable).

Locate telecommunications pathways away from sources of EMI such as electrical power wiring and transformers, radio frequency (RF) sources and transmitters, large motors and generators, induction heaters, arc welders, x-ray equipment, and copiers.

The following precautions should be considered to reduce interference from sources of EMI:

- Use grounded metallic pathways to reduce inductive noise coupling between the telecommunications cabling and sources of EMI. Cable installation close to a grounded metallic surface will also reduce inductive noise.
- Use sheathed power cables (e.g., Romex) or other branch circuit cable constructions (e.g., taped, twisted, or bundled) that prevent separation of the line, neutral, and grounding conductors to reduce EMI from the power conductors.
- The use of surge protectors in branch circuits can limit the propagation of electrical surges and associated interference. In the United States, separation requirements between telecommunications and other types of circuits are provided in Article 800-52 of the *NEC*. General building considerations that have an impact on both safety and EMI include:
  - Structural lightning protection.
  - Electrical surge protection.
  - Grounding and bonding.
  - Faulty electrical wiring.

### **Grounding and Bonding**

In addition to creating a serious safety risk, improper grounding of telecommunications pathways may increase susceptibility to EMI.

When grounding telecommunications pathways, ensure that:

- The installation conforms to applicable practices and codes the *NEC*, and local building codes
- An approved ground is available in the telecommunications terminal room (MDF/BDF/IDF) for cross-connect frames and patch panel racks.

### **Firestopping**

All horizontal pathways that penetrate fire-rated barriers must be firestopped in accordance with applicable codes

### **Wet Locations**

Intrabuilding horizontal pathways shall be installed in “dry” locations that protect cables from moisture levels that are beyond the intended operating range of “inside” premises cable. For example, slab-on-grade constructions where pathways are installed underground or in concrete slabs that are in direct contact with soil (e.g., sand, gravel, etc.) are considered to be “wet locations.”

## **Hazardous Locations**

When telecommunications horizontal pathways or cabling are placed in a hazardous location, such as an explosive or combustible atmosphere, observe all requirements of applicable codes.

## **Types of Horizontal Pathways**

The main types of horizontal pathways are:

- Underfloor ducts (one-level or two-level).
- Cellular floors.
- Conduit.
- Cable tray.
- Access (raised) floors.
- Ceiling distribution.

Many buildings require a combination of two or more of these systems to meet all distribution needs. For example, an office area in a building may require an underfloor or overhead system, while an isolated voice/data outlet location in the same building may be best served by an individual conduit.

NOTE: Because some local codes specify the type of horizontal pathway to be used, check all applicable codes and regulations before selecting a type of pathway.

## **Sizing Considerations for Horizontal Pathways**

The size requirements for horizontal pathways depend on the following considerations:

- Usable floor space served by the pathway
- Maximum occupant density (e.g., floor space required per individual voice/data outlet)
- Cable density (e.g., quantity of horizontal cables planned per individual voice/data outlet)
- Cable diameter
- Pathway capacity (requires that fill factor be taken into account)
- Cabling requirements for other cabling systems

## **Usable Floor Space**

The usable floor space (also called office space) is generally considered to be the building area used by occupants for their normal daily work functions. For planning purposes, this space should include hallways, but not other common areas of the building.

## **Occupant Density**

The standard floor space allocation used in an office environment is one individual voice/data outlet for every 10 m<sup>2</sup> (100 ft<sup>2</sup>) of usable floor space.

NOTE: In cases where the voice/data outlet density will be greater than one office per 10 m<sup>2</sup> (100 ft<sup>2</sup>) of usable floor space, or where there will be more than three outlets required for each voice/data outlet, the pathway capacity must be increased accordingly.  
(I.e. Computer Labs)

## Cable Density

The designer should plan for a pathway capacity that accommodates a minimum of three horizontal cable runs per individual voice/data outlet. Although only two cable runs are required, additional capacity will facilitate additions and changes to horizontal cabling as user needs and applications evolve. Also, consider other signaling system requirements.

## Cable Diameter

The following table lists typical ranges of cable diameter for three recognized horizontal cabling media. These values are provided for planning purposes only. It is strongly recommended that the designer check the actual diameter of the cable being used before determining pathway size requirements. The Superior Essex 10Gain XP 6A is an F-UTP cable, 23 gauge with an O.D. of .30.

**Table 4.1: Typical ranges of cable diameter**

| Horizontal Cable Type                 | Typical Range of Overall Diameter     |
|---------------------------------------|---------------------------------------|
| 4-pair 100 $\Omega$ UTP or ScTP (FTP) | 3.6 mm to 6.3 mm (0.14 in to 0.25 in) |
| 2-fiber optical cable                 | 2.8 mm to 4.6 mm (0.11 in to 0.18 in) |
| 4-pair 100 $\Omega$ STP               | 7.9 mm to 11 mm (0.31 in to 0.43 in)  |

NOTES: FTP = Foiled twisted-pair      STP = Shielded twisted-pair  
ScTP = Screened twisted-pair      UTP = Unshielded twisted-pair

## Determining Pathway Size

Most pathways are provided with design guidelines, including fill factors from the manufacturer. Different types of pathways have different fill factors. The NEC code is also a source for design guidelines.

## Design Considerations for Conduit Distribution

### Suitable Conduit

The types of conduit suitable for use in buildings are:

- Intermediate metal conduit.
- Rigid metal conduit.
- Rigid non-metallic conduit.
- Electrical metallic tubing.
- Other permitted by the appropriate electrical codes.

**IMPORTANT:** Flexible conduit (such as metal flex conduit) is not recommended for use in buildings.

Use flexible conduit only in situations where it is the only practical alternative.

NOTE: If flexible conduit must be used, increase the conduit size by one trade size.

### Acceptable Conduit Runs

Design and install conduit runs to:

- Run in the most direct route possible (usually parallel to building lines), preferably with no more than two 90 degree bends between pull points or pull boxes (PBs).
- Contain no 90 degree condulets (also known as LBs).

- Contain no continuous sections longer than 30 m (100 ft).
- If shielded cable is used it shall be bonded to ground on one or both ends, in accordance with national or local requirements (ANSI/TIA/EIA-607).
- Withstand the environment to which they will be exposed.

NOTES: For runs that total more than 30 m (100 ft) in length, insert pull points or PBs so that no segment between points/boxes exceeds the 30 m (100 ft) limit. It is recommended that total conduit runs be kept to 45 m (150 ft) or less (including the sections through pull boxes).

### Unacceptable Conduit Runs

Do not run conduit:

- On top of cellular floor cells.
- Crosswise to cellular floor cells.
- Through areas in which flammable material may be stored.
- Over or adjacent to:
  - Boilers.
  - Incinerators.
  - Hot water lines.
  - Steam lines.

In initial installations, do not use conduit in lieu of feeder ducts between the distribution ducts and the TR, or to supplement the feeder capacity of the system.

### Conduit Capacity

The following table provides guidelines used by ANSI/TIA/EIA-569-A on cable capacity for conduits ranging from 16 mm (1/2 trade size) to 103 mm (4 trade size).

| Inside Diameter<br>mm | Trade Size | Cable Outside Diameter<br>mm (in) |               |               |               |               |               |               |                |                |                |
|-----------------------|------------|-----------------------------------|---------------|---------------|---------------|---------------|---------------|---------------|----------------|----------------|----------------|
|                       |            | 3.3<br>(0.13)                     | 4.6<br>(0.18) | 5.6<br>(0.22) | 6.1<br>(0.24) | 7.4<br>(0.29) | 7.9<br>(0.31) | 9.4<br>(0.37) | 13.5<br>(0.53) | 15.8<br>(0.62) | 17.8<br>(0.70) |
| 16                    | 1/2        | 1                                 | 1             | 0             | 0             | 0             | 0             | 0             | 0              | 0              | 0              |
| 21                    | 3/4        | 6                                 | 5             | 4             | 3             | 2             | 2             | 1             | 0              | 0              | 0              |
| 27                    | 1          | 8                                 | 8             | 7             | 6             | 3             | 3             | 2             | 1              | 0              | 0              |
| 35                    | 1-1/4      | 16                                | 14            | 12            | 10            | 6             | 4             | 3             | 1              | 1              | 1              |
| 41                    | 1-1/2      | 20                                | 18            | 16            | 15            | 7             | 6             | 4             | 2              | 1              | 1              |
| 53                    | 2          | 30                                | 26            | 22            | 20            | 14            | 12            | 7             | 4              | 3              | 2              |
| 63                    | 2-1/2      | 45                                | 40            | 36            | 30            | 17            | 14            | 12            | 6              | 3              | 3              |
| 78                    | 3          | 70                                | 60            | 50            | 40            | 20            | 20            | 17            | 7              | 6              | 6              |
| 91                    | 3-1/2      |                                   |               |               |               |               |               | 22            | 12             | 7              | 6              |
| 103                   | 4          |                                   |               |               |               |               |               | 30            | 14             | 12             | 7              |

The previous table provides guidelines on cable capacity for horizontal conduits that have no more than two 90 degree bends (180 degrees total) and are no longer than 30 m (100 ft). Additional information on telecommunications conduit fill is provided in ANSI/TIA/EIA-569-B.

NOTE: The previous table shows the conduit fill ratio guidelines for horizontal cables; however, the number of cables that can be installed is actually limited by the allowed maximum pulling tensions of the cables. This fill requirement does not apply to sleeves, header ducts, underfloor systems, access floors, and conduit runs without bends and under 15 m (50 ft). Fill ratios can be increased further by use of lubricants.

The TIA Working Group TR 42.3 has investigations pending on the subject of allowable fill for telecommunications pathways. Monitors pull force closely during installation to ensure that the manufacturer’s pull force requirements are never exceeded. Pull force is determined by several factors, including the:

- Cable type and quantity.
- Conduit type.
- Conduit size.
- Conduit length.
- Conduit orientation.
- Number and configuration of conduit bends.
- Selection of lubricants used during installation.

Since the first portion of cable may be damaged during the pulling operation, it should be cut off prior to terminating.

### Determining Conduit Size

The following is a sample calculation to determine the size of a horizontal conduit, based on the preceding information and guidelines.

| Step | Determining the Floor Space that a Conduit Can Serve   | Example   |
|------|--|---|
| 1    | Measure the usable floor space to be served by the horizontal conduit.   | 100 m <sup>2</sup> (1000 ft <sup>2</sup> )  |
| 2    | Divide the usable floor space by the maximum occupant density (required per individual work area [IWA]).   | 100 m <sup>2</sup> (1000 ft <sup>2</sup> )<br>÷ <u>10 m<sup>2</sup> (100 ft<sup>2</sup>)</u><br>10 IWAs |
| 3    | Multiply by the maximum number of cables per IWA. (See Cable Density in this section.)   | 10 IWAs<br>x <u>3 cables per IWA</u><br>30 cables   |
| 4    | Determine the maximum diameter of the horizontal cable to be used.<br>(Telecommunications cables of different types may be placed together in the same conduit.)               | ∅ 5.8 mm (0.23 in)  |
| 5    | Use the table in Conduit Capacity in this section to determine the conduit size that is most suitable for holding a quantity of 30 cables with a diameter of 6.1 mm (0.24 in). | 64 mm (2.5 in)  |

### Recommended Conduit Capacity

To ensure proper capacity for cabling, a conduit from the BDF/IDF should not extend to more than two outlet boxes and must not extend to more than three. Conduit size is generally designed so its diameter increases incrementally as the run approaches the TR from the furthest outlet box. The conduit size for horizontal cable must accommodate:

- Multiple building occupants.
- Cables placed at different times.

Conduit capacity calculation to determine the cross-sectional area of a cable or conduit from its nominal diameter:

$$\text{Cross-sectional area} = (0.785) \times (\text{Diameter})^2$$

Treat multi-conductor cables (e.g., two or more conductors under a shared jacket) as a single cable for calculating percentage conduit fill area. For cables with an elliptical cross-section, use the larger diameter of the ellipse as the diameter in the equation above.

### Designs with Conduit Bends

The following table provides guidelines for adapting designs to conduits with bends.

NOTE: Consider an offset as equivalent to a 90 degree bend.

**Table 4.12: Adapting designs**

| <b>If a Conduit Run Requires...</b>                 | <b>Then...</b>  |
|---|---|
| More than two 90 degree bends                       | Provide a pull box (PB) between sections with two bends or less.                      |
| A reverse bend (between 100 degree and 180 degree)  | Insert a pull point or PB at each bend having an angle from 100 degree to 180 degree. |
| A third 90 degree bend (between pull points or PBs) | For this additional bend, derate the design capacity by 15 percent.                   |

### Conduit Terminations

Ream all conduit ends and fit them with an insulated bushing to eliminate sharp edges that can damage cables during installation or service. Conduits that enter a BDF/IDF should terminate near the corners to allow for proper cable racking. Terminate these conduits as close as possible to the wall where the backboard is mounted (to minimize the cable route inside the BDF/IDF). Terminate conduits that protrude through the structural floor 25 mm to 75 mm (1 in to 3 in) above the surface. This prevents cleaning solvents or other fluids from flowing into the conduit.

## Fire Stopping

- Provide fireproof seals in accordance with the National Fire Protection Association (NFPA) and the National Electric Code (NEC), Article 200-221 and EIA/TIA 569 standards.
- Fire stops all penetrations in accordance with the current edition of the National Electrical Code.
- Do not use concrete for fire stopping on cable trays, wire ways or conduit. Contractors who use this method will be required to replace all cables affected.

## Pull Boxes (PBs) for Conduits

Install:

- PBs in easily accessible locations.
- Horizontal cabling boxes immediately above suspended ceilings.

NOTE: The following PB information applies to inside plant cables only.

For direct access to a box, provide a suitable, marked, hinged panel (or equivalent) in the suspended ceiling. This access panel can also serve as the cover for the box.

The following figure shows recommended box configurations.

**Figure 4.26: Recommended box configurations**

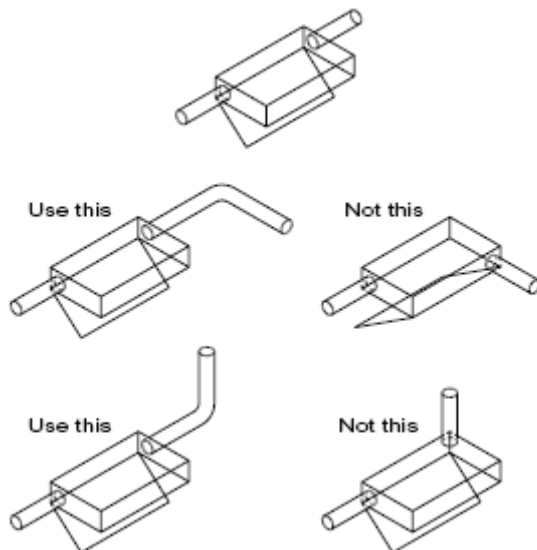

## Sizes and Purposes of Boxes, Slip Sleeves, and Gutters

For horizontal cable, the box, slip sleeve, or gutter's:

- Width and depth must be adequate for fishing, pulling, and looping the cable.
- Length must be 12 times the diameter of the largest conduit. In some cases (e.g., when large cables are planned to serve multiple voice/data outlets), a box length of 16 times the diameter of the largest conduit may be appropriate. These requirements facilitate:
  - Pulling cable into the box.
  - Looping cable for pulling into the next length of conduit.

## Boxes for Pulling and Looping Cable

Boxes for pulling and looping cable are suitable only for cables that have an outside diameter of 50 mm (2 in) or less. If the cable is larger than 50 mm (2 in) in diameter, do not locate the box in the ceiling; route the cable and conduit down a wall or column. PBs must be placed in readily accessible locations. Place a PB in interstitial ceiling space only if the PB is:

- Listed for that purpose, and
- Placed above a suitably marked, removable ceiling panel.

Do not use PBs for splicing cable.

NOTE: Splices are not permitted in twisted-pair horizontal cables.

Place PBs in sections of conduit that:

- Are 30 m (100 ft) or more in length, or
- Contain more than two 90 degree bends, or
- Contain a reverse bend.

Do not use a PB in lieu of a bend. Align conduits that enter the PB from opposite ends with each other.

### Minimum space requirements in pull boxes having one conduit each in opposite ends of the box

| Maximum Trade Size of Conduit | Size of Box    |                 |               | For Each Additional Conduit Increase Width |
|-------------------------------|----------------|-----------------|---------------|--|
|                               | Width          | Length          | Depth         |  |
| 21 mm (3/4)                   | 100 mm (4 in)  | 300 mm (12 in)  | 75 mm (3 in)  | 50 mm (2 in)                               |
| 27 mm (1)                     | 100 mm (4 in)  | 400 mm (16 in)  | 75 mm (3 in)  | 50 mm (2 in)                               |
| 35 mm (1-1/4)                 | 150 mm (6 in)  | 500 mm (20 in)  | 75 mm (3 in)  | 75 mm (3 in)                               |
| 41 mm (1-1/2)                 | 200 mm (8 in)  | 675 mm (27 in)  | 100 mm (4 in) | 100 mm (4 in)                              |
| 53 mm (2)                     | 200 mm (8 in)  | 900 mm (36 in)  | 100 mm (4 in) | 125 mm (5 in)                              |
| 63 mm (2-1/2)                 | 250 mm (10 in) | 1050 mm (42 in) | 125 mm (5 in) | 150 mm (6 in)                              |
| 78 mm (3)                     | 300 mm (12 in) | 1200 mm (48 in) | 125 mm (5 in) | 150 mm (6 in)                              |
| 91 mm (3-1/2)                 | 300 mm (12 in) | 1350 mm (54 in) | 150 mm (6 in) | 150 mm (6 in)                              |
| 103 mm (4)                    | 375 mm (15 in) | 1520 mm (60 in) | 200 mm (8 in) | 200 mm (8 in)                              |

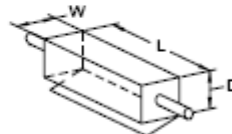

## **Ceiling Distribution Systems**

### **Introduction**

Ceiling distribution systems use the interstitial space between:

- The structural ceiling (physically part of the roof or floor above), and
- An accessible ceiling grid suspended below the structural ceiling.

The methods of ceiling cable distribution described in this section are generally acceptable if the:

- Ceiling is adequate and suitable.
- Ceiling space is available for cabling pathways.
- Ceiling space is used only for horizontal cables serving the floor below.
- Ceiling access is controlled by the building owner.
- Code requirements for design, installation, and pathways are met.
- Building owner is aware of his or her responsibility for any damage, injury, or inconvenience to occupants that may result from technicians working in the ceiling.
- Areas used for cabling pathways are fully accessible from the floor below (e.g., not obstructed by fixed ceiling tiles, drywall, or plaster).
- Ceiling tiles are removable and placed at a height of no greater than 3.4 m (11 ft) above the finished floor.

Connecting hardware must be mounted in locations that are readily accessible. Mounting of certain types of hardware (e.g., CP connectors) in a suspended ceiling space may be acceptable, provided that:

- The space is accessible.
- Building fixtures, equipment, or heavy furniture (e.g., file cabinets weighing 45 kg [100 lb] or more) do not compromise access.
- Access does not disturb building occupants.
- Hardware is protected from physical abuse and foreign substances.

In all cases, in the United States, the use of connecting hardware in ceiling spaces shall conform to the local building codes. Telecommunications outlets/connectors must not be located in the ceiling space.

### **Ceiling Zones Method**

In the ceiling zones method of ceiling distribution, divide the usable floor area into zones of 34 m<sup>2</sup> to 84 m<sup>2</sup> (365 ft<sup>2</sup> to 900 ft<sup>2</sup>) each. When convenient, it is preferable that zones be divided by building columns. Pathways to each zone may be provided using cable trays within the ceiling area or enclosed conduits or raceways. The raceways, conduits, or cable trays should extend from the TR to the midpoint of the zone. From that point, the pathway should extend to the top of the utility columns or wall conduit.

NOTE: Plenum-rated cable tray or raceway may be required. In the United States, refer to the *NEC*, Section 300-22 *NEC*, and Section 318.4 for restrictions on the use of cable trays.

## Typical Ceiling Zone Distribution Using Conduit

The following figure shows a typical ceiling distribution system using zone conduit to telecommunications zones.

**Figure 4.28: Using zone conduit**

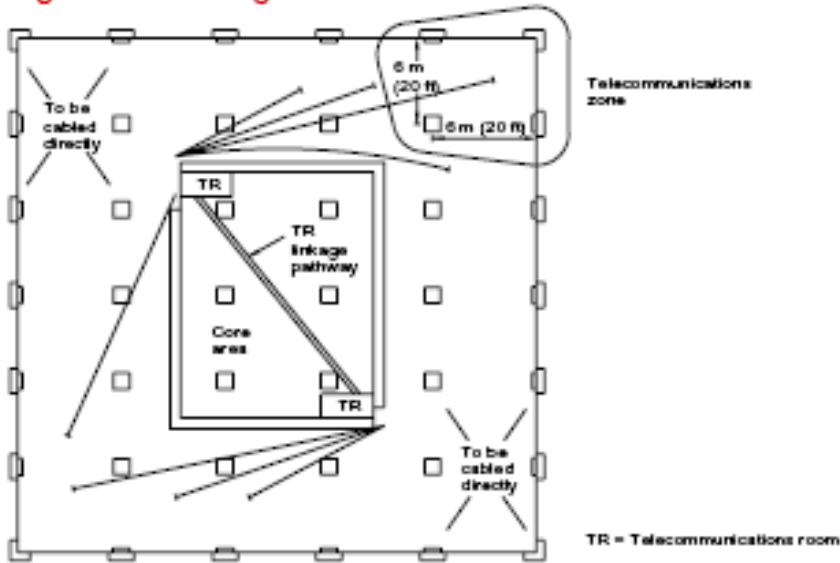

NOTE: This figure represents only a schematic depiction of a ceiling distribution system. Actual pathways to ceiling zones should be organized in a neat and orderly fashion to facilitate ongoing service and maintenance of the ceiling pathways.

## Ceiling Zones

The figure below shows a typical zoned ceiling distribution system (plan view).

**Figure 4.29: Typical zoned ceiling (plan view)**

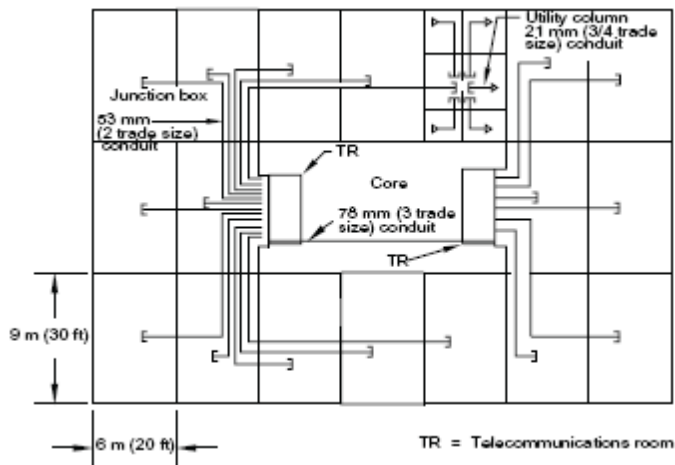

NOTE: Only one zone is completed.

The following figure shows a typical conduit-based ceiling zone (elevation view).



## Choosing the Ceiling Panels

Choose the type of ceiling panel to install according to the following table.

**Table 4.17: Guidelines for choosing ceiling panels**

| Use a Ceiling Panel that Is... | For a...  |
|--------------------------------|---|
| Readily removable              | Lay-in type panel on either: <ul style="list-style-type: none"><li>• Single support channel, or</li><li>• Double support channel.</li></ul> NOTES: Securely install and brace support channels to prevent both vertical and horizontal movement.<br>Use panels built from stable materials to reduce panel damage from periodic handling. |
| Not readily removable          | Lock-in type panel that requires a conduit system.  |

## Restrictions on Ceiling Cabling

Cabling within ceilings used as a plenum for environmental air must conform to the requirements of:

- National codes and regulations.
- In the United States, the *NEC*, Section 300-22.
- In Canada, *CSA-C22.1*, Section 12-010.

## Ceiling Zone Conduit Restrictions

A zone conduit system may be allowed in an air plenum ceiling if:

- Conduits terminate in junction boxes, and
- Short runs of smaller conduit are extended from the junction boxes to the voice/data outlets.

**IMPORTANT:** Verify the use of ceiling zones in air plenums with code authorities. In the United States, local codes may deviate.

## Pathway and Cable Support

Every ceiling distribution system must provide proper support for cables from the TR to the voice/data outlets it serves.

Ceiling panels, support channels (T-bars), and vertical supports are not proper supports. Ceiling conduits, raceways, cable trays, and cabling must be suspended from or attached to the structural ceiling or walls with hardware or other installation aids specifically designed to support their weight. The pathways must:

- Have adequate support to withstand pulling the cables.
- Be installed with at least 75 mm (3 in) of clear vertical space above the ceiling tiles and support channels (T-bars) to ensure accessibility. Do not allow horizontal pathways or cables to rest directly on or be supported by ceiling panels, support channels (T-bars), vertical supports, or other components of the suspended ceiling. It is important to provide sufficient space between the suspended ceiling structure and the telecommunications

pathways/cables to install, maneuver, and store ceiling tiles during service. When sufficient space is available above the pathway, provide up to 150 mm (6 in) between the suspended ceiling and the cabling pathways.

- Data drops for wireless access points in the T-Bar ceiling require the use of the CADDY #512 HD T-grid box hangers at all locations. The installation of a 2x4" junction box and this is to be supported by wire as required by code.
- Where building codes permit telecommunications cables to be placed in suspended ceiling spaces without conduit, ceiling zone distribution pathways may consist of:
  - Cable trays, and/or
  - Open-top cable supports (J-supports).

NOTE: When using J-supports, locate them on 1.2 m (4 ft) to 1.5 m (5 ft) centers to adequately support and distribute the cable's weight. These types of supports may typically hold up to fifty 6.4 mm (0.25 in) diameter cables. Concern and some evidence exist that certain cable support devices can have a detrimental effect on transmission performance of higher performance cabling systems. Devices that have small surface areas to support the cable laying horizontally in them are the types of devices in question. When a choice exists, it would be prudent to select a device with a wider surface area to support the cable as a precaution against potential problems. Another precaution would be to reduce the distance between the support devices, and support channels (T-bars). In renovations, care must be taken, as asbestos is known to be blown on structural steel.

Horizontal Cabling will be supported 12 inches above ceiling surfaces and shall not attach to other systems as a means of support. Cable will be run through a central corridor and branch out to the station/outlet areas in a tree design.

For large quantities of cables (50 to 75) that converge at the TR and other areas, provide cable trays or other special supports that are specifically designed to support the required cable weight and volume.

### **Termination Space**

Allow maximum wall space in the BDF/IDF for the horizontal cable terminations. Spare cables may be left in the ceiling for future use. This practice reduces:

- Inconvenience to office personnel.
- The time and expense associated with voice/data equipment moves, adds, and changes.

### **Cable Tray Design for Ceiling Systems**

#### **Cable Tray Systems**

Cable tray systems are commonly used as distribution systems for cabling within a building. They are often preferable to rigid conduit and raceway systems because of their greater accessibility and ability to accommodate change and cable tray systems:

- Must be rigid, prefabricated support structures that support telecommunications cables and cabling.
- Must be installed to meet:

Although it may be allowed by some building codes, telecommunications distribution designers are strongly advised not to use shared cable trays to distribute

telecommunications and power cables. If trays or wireways are shared, the power and telecommunications cables must be separated by a grounded metallic barrier. When a tray is used in the ceiling area, provide conduit from the tray to the outlets or zones, except in cases where loose cables are permitted by and meet the applicable codes.

NOTES: The inside of a cable tray must be free of burrs, sharp edges, or projections that can damage cable insulation.

### Types of Cable Trays

The basic types of cable trays are described in the following table.

**Table 4.18: Cable trays**

| Type of Cable Tray | Structural Description  |
|--------------------|---|
| Ladder             | Two side rails connected by individual transverse members   |
| Ventilated trough  | A ventilated bottom with side rails   |
| Ventilated channel | Channel section with a one-piece bottom no more than 150 mm (6 in) wide                             |
| Solid bottom       | Solid bottom with longitudinal side rails   |
| Spine              | Open tray having a central rigid spine with cable support ribs along the length at 90 degree angles |

### Cable Tray Dimensions

Dimensions for four common types of cable trays are shown in the table below.

NOTES: Consult cable tray manufacturers for tolerances of specific models.

The dimensions below illustrate a standard variety of tray sizes to suit most applications for horizontal cable distribution. Other sizes and designs are available to accommodate special needs and installations. Consult cable tray manufacturers for a comprehensive listing of standard models.

**Table 4.19: Cable trays (common types)**

|   | Ladder         | Ventilated Trough | Ventilated Channel | Solid-Bottom   |
|---|----------------|-------------------|--------------------|----------------|
| Lengths   | 3.7 m (12 ft)  | 3.7 m (12 ft)     | 3.7 m (12 ft)      | 3.7 m (12 ft)  |
|   | 7.3 m (24 ft)  | 7.3 m (24 ft)     | 7.3 m (24 ft)      | 7.3 m (24 ft)  |
| Widths (Inside)   | 150 mm (6 in)  | 150 mm (6 in)     | 75 mm (3 in)       | 150 mm (6 in)  |
|   | 300 mm (12 in) | 300 mm (12 in)    | 100 mm (4 in)      | 300 mm (12 in) |
|   | 450 mm (18 in) | 450 mm (18 in)    | 150 mm (6 in)      | 450 mm (18 in) |
|   | 600 mm (24 in) | 600 mm (24 in)    | — —                | 600 mm (24 in) |
|   | 750 mm (30 in) | 750 mm (30 in)    | — —                | 750 mm (30 in) |
|   | 900 mm (36 in) | 900 mm (36 in)    | — —                | 900 mm (36 in) |
| NOTE: The side rail outside depths (height) can be as much as 32 mm (1-1/4 in) more than the inside loading depth for ladder, ventilated trough, and solid bottom cable tray. |                |                   |                    |                |
| Depths  | 75 mm (3 in)   | 75 mm (3 in)      | 32 mm (1-1/4 in)   | 75 mm (3 in)   |
|   | 100 mm (4 in)  | 100 mm (4 in)     | 45 mm (1-3/4 in)   | 100 mm (4 in)  |
|   | 125 mm (5 in)  | 125 mm (5 in)     | — —                | 125 mm (5 in)  |
|   | 150 mm (6 in)  | 150 mm (6 in)     | — —                | 150 mm (6 in)  |
| Rung spacing  | 150 mm (6 in)  | — —               | — —                | — —            |
|   | 225 mm (9 in)  | — —               | — —                | — —            |
|   | 300 mm (12 in) | — —               | — —                | — —            |
|   | 450 mm (18 in) | — —               | — —                | — —            |
| Radii   | 300 mm (12 in) | 300 mm (12 in)    | 300 mm (12 in)     | 300 mm (12 in) |
|   | 600 mm (24 in) | 600 mm (24 in)    | 600 mm (24 in)     | 600 mm (24 in) |
|   | 900 mm (36 in) | 900 mm (36 in)    | 900 mm (36 in)     | 900 mm (36 in) |
| Degrees of arc  | 30°            | 30°               | 30°                | 30°            |
|   | 45°            | 45°               | 45°                | 45°            |
|   | 60°            | 60°               | 60°                | 60°            |
|   | 90°            | 90°               | 90°                | 90°            |
| Transverse element spacing  | — —            | 100 mm (4 in)     | — —                | — —            |

**Capacity of Cable Trays**

The working load capacity of a cable tray system is determined by both the:

- Static load capacity of the tray, and
- The length of the support span.

The cable tray specifications are provided in the *NEC*, Section 318-9(b)

Multiconductor Control and/or Signal Cables Only; Section 318-9(d),

Solid-Bottom Cable Tray; and Section 318-9(e)

(2), Ventilated Channel Cable Trays.

NOTE: Total cable weight per meter (foot) is rarely the limiting factor in determining the allowable cable tray fills for telecommunications cables. For horizontal cables, the allowable fill volume will usually be obtained before the allowable weight per meter (foot) is reached.

## **Supporting Cable Trays**

Support cable trays by installing:

- Cantilever brackets.
- Trapeze supports.
- Individual rod suspension brackets.

Support centers must be spaced according to the cable load and span, as specified for the cable tray's type and class by the manufacturer and applicable electrical codes. Place supports so that connections between sections of the cable tray are between the support point and the quarter section of the span. Trays and wireways are usually supported on 1.5 m (5 ft) centers, unless they are designed for greater spans. A support must also be placed within 600 mm (24 in) on each side of any connection to a fitting.

## **Marking and Grounding Cable Trays**

All metallic cable trays must be grounded, but should not be used as grounding conductors for equipment. Clearly mark all cable trays and grounding conductors in accordance with ANSI/TIA/EIA-606 and ANSI/TIA/EIA-607.

## **Conduit and Raceway Design for Ceiling Systems**

### **Ceiling Home-Run Method Using Conduit**

In a home-run ceiling conduit system, place a continuous run of conduit from the WA outlet boxes to the BDF/IDF. Each home-run conduit can serve from one to three outlet boxes, depending on the design and conduit size. For conduits that serve:

- One box, an inside diameter of 19 mm (0.75 in) or greater is recommended.
- Two boxes, an inside diameter of 25 mm (1 in) or greater is recommended.
- Three boxes, an inside diameter of 32 mm (1.25 in) or greater is recommended.

NOTES: Although home-run conduits may serve up to three outlet boxes, each horizontal cable run may only serve a single telecommunications outlet (e.g., no looping or bridge taps). Always observe the air plenum requirements in the *NEC* when using this method of distribution.

Departments planning to install their own raceway system should be aware that the standards require all wire be concealed. Fishing the walls, wire mold, and conduit placement are three methods of concealing wires.

However, as part of a long-range structural plan, if conduit to a station jack location is desired we recommend:

- 1" conduit stubbed and capped for protection in the ceiling with a pull string
- 5 Square telecommunications work box recessed into the wall (junction box is required for every work area location).
- Mounting height:
  - Standard outlet center: 18" AFF (above finished floor)
  - Wall outlet center: 54" AFF
  - Handicapped wall outlet: 48" AFF

## Telecommunications Outlet Box Standard

- Randl - 5 Square Telecommunications Box - # T-550017
- 5 in. square x 2.875 in. deep box with cable management
- 64 in (1050 cm<sup>3</sup>) volume
- (1) 1" (1) 1 ¼" knockouts each side
- (1) ½" back knockout

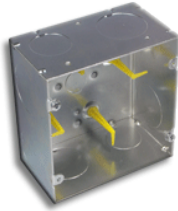

If the conduit transports more than telecommunications, departments may want to reassess the conduit's size to provide for additional voice or data communications demands. In any situation where a conduit is being installed, the fill ratio must be 40%.

When installing conduits, if there are more than two 90-degree angle turns in the conduit, a pull box is required. When installing a tray as part of an open raceway system, the tray must be more than one (1) foot from an electrical source (i.e. fluorescent light).

To facilitate future cable installations a new pull string, tied off at both ends shall be installed in conduit simultaneously with the pull-in of cable.

### **Voice/Data, Work Areas (WAs)**

WAs are those spaces in a building where occupants normally work and interact with their telecommunications equipment. It is important that the WA be properly designed to accommodate the needs of both the occupants and the equipment that occupants use. WA equipment may include (but is not limited to):

- VOIP Telephones.
- Fax machines.
- Network Printer.
- Desktop computers.

Each of these devices may require access to the horizontal cabling via a cord plugged into the telecommunications outlet (TO) that is located within the WA.

NOTE: The term outlet often must be interpreted in the context within which the word is used. In a general sense, a WA outlet is simply a location that terminates the horizontal cabling system, thus providing access to the cabling system for occupant devices. More specifically, however, this location is often comprised of both connecting hardware (e.g., a "jack" or receptacle that attaches to the cable) and the housing (e.g., an electrical box) into which the connecting hardware is placed. In this latter sense, the term outlet is often used to refer to the box, the receptacle, or both.

## **General**

Many commercial buildings are now designed to be easily reconfigured as its occupants' needs evolve. This trend has led to "open office" and "open workspace" designs in which the available WA space is divided by modular furniture and partitions, rather than by fixed walls. These partitions and furniture typically provide for:

- Cable pathways.
- TOs.

## **Work Area Outlet Locations**

Consideration should be given to the following guidelines for planning the location of WA outlets.

- Each occupant WA must have a minimum of two outlet location. For WAs in which it may be difficult to install future additional outlets (e.g., in private offices), a minimum of two outlet locations should be provided and located for equipment access flexibility (e.g., on opposing walls). A minimum of two connectors per angled faceplate outlet installed in each WA.
- The WA angled faceplate outlet should be located near a power outlet (e.g., within 1 m [3 ft]) and installed at the same height.
- The wall outlet locations shall be 5 Square Telecommunications Outlet Boxes.
- Floor outlet boxes and monuments, and the cords extending from them, can present a tripping hazard. The location of these outlets should be coordinated with furniture to minimize such hazards.
- Standard complement of cables for each WA is (2) Category 6A 10G AXi plenum or Non-Plenum rated cables depending on the HVAC system of the building. Palomar College District standard in is Non-Plenum 10G AXi Category 6A System, (10 Gigabit), rated, TIA/EIA-568-B-10. **eXtreme® 10G CAT 6A SlimLine Patch Cords must be provided to eliminate crosstalk at both the workstation and patch panel ends.**

## **Work Area Cords**

WA cords (sometimes called "line cords" or "station cords") extend from the TO to the WA equipment. The telecommunications distribution designer must convey the importance of good WA components and cabling practices to the owner. Although WA cabling is critical to assuring good horizontal channel performance, it is often subject to abuses (e.g., using sub grade cords in position to be physically formed).

Cords that are used to connect WA equipment are as critical to transmission performance as embedded horizontal cable runs. For WA cords and other equipment cables that connect to the horizontal cabling, follow the performance requirements described in TIA/EIA-568-B.2-10. Requirements for Category 6A cords are specified in TIA/EIA-568-B.2-10. The combined length of equipment cables, WA cords, and patch cords in the WA and telecommunications room (BDF/IDF) must not exceed 10 m (33 ft).

All cable products must conform to the Districts standard for cable systems, Non-Plenum rated Category 6A 10G, (10 Gigabit), in buildings that require Plenum rated cable in some areas the entire building shall be PLENUM, rated, TIA/EIA-568-B.2-10, for

network bandwidth of 10 G on all cable systems, cable, patch panels and jacks. All cable shall be shielded cable to help eliminate crosstalk. All workstation cords and patch panel cords must also be included in the 10G system, **eXtreme® 10G CAT 6A SlimLine Patch Cords must be provided to eliminate crosstalk at both the workstation and patch panel ends.**

All parts must be part of the 10G system to meet the manufacturer's Lifetime warranty standard for the data cable system.

- All cabling run outside of interior walls will be encapsulated. All conduits, raceways, and ladder trays, etc. must conform to Category 6A bend radius requirements. Surface mounted conduits and raceways will have ceiling entry/exit adapters and coupler clips. Surface mounted outlet box supports (back plates), will be attached with no less than two screws each and the outlet box will be secured to the back plate without the modular outlet plate (angled faceplate) holding the box to the back plate. Where ever possible flush wall outlet plates would be preferred using standard single gang screw mount low voltage brackets – Class 2 use only – (ERICO CADDY type). The outlet plate will be designed to accept modular connectors, which can snap into and out of the open ports of the wall plate (outlet plate).
- The color of all outlet plates will be ALMOND and shall be ANGLED. RJ-45 modular connectors shall be compatible with the eXtreme 10G CAT 6A system and must be equal the TIA/EIA-568-B.2-10 performance up to 500 MHz to support 10G BASE-T networks.
- The connectors shall be CAT6A QuickPort design, terminated using the TIA/EIA 568-B.2-10 wiring configuration compatible with USOC 4 pair terminations. The CAT6A jack shall be shielded for all CAT6A installations. The color of all DATA modular connectors shall be BLUE.

Note – For AV applications the color of the jack shall be BLACK.



- 
- Cable must be Superior Essex 10Gain XP 6A F-UTP cable, 23 gauge (6H-272-2A) 8-conductor solid copper wire exceeding TIA/EIA-568-B.2-10 requirements by 3 dB. Must exceed the TIA/EIA-568-B.2-10 performance up to 500 MHz to support 10 Gigabit BASE-T networks. If part of the building requires a Plenum application (6H-272-2B) then the entire building then it is required that the entire building shall be Plenum. Contractors should check building HVAC plans for cable requirements. The color of the cable for DATA shall be BLUE.

- Both ends of the cable must be clearly and permanently marked for identification not less than 6 inches or more than 12 inches from the end of the cable. Both Voice/Data must be labeled at end users location with symbols and numbers indicating their system and specific port or station location.
- A minimum of 12-inch tails at each location for termination and identification is required. The total length of each cable run shall not exceed 100 meters including workstation patch cable and patch panel patch cable.
- At the IDF/HUB STACK each run will terminate on an ANGLED 48 ports Leviton's eXtreme 10G AXi Category 6A System rated patch panels.



- BLACK Category 6A, Leviton's eXtreme® 10G AXi Category 6A System SlimLine Patch Cords system rated patch cables with snag less boots will be provided for each rack and wall mount rack for one to one connection from the patch panel to the data equipment.
- Labeling of patch panels, cable and wall plates – Each cable shall be labeled at each end and the faceplates labels will correspond with the labels on the cable. The label scheme for each of the buildings will be as follows:
  - Destination panels will be identified by the floor and by A-Z, example:
    - Patch Panel 1A-C            Patch Panel 2A-C
  - Wall outlets will be identified by the floor, IDF room, destination panel and port, examples:
    - 1.NS101A1-48 (1<sup>st</sup> floor, roomNS101, panel A, port #)    2.NS210A1-48
- MUTOA (Multi-User Telecommunications Outlet Adapter) is not permitted in design or practice on the campus of Palomar
- Air Blown Fiber (ABF) shall be determined by the overall capacity of the building as to the amount of fiber strands. The district standard on the minimum strands for each building is 12 strands from the Information Services MDF to the building MDF.
- ABF fiber shall be single mode fiber; standard connector type shall be LC connectors. Fiber terminations shall use termination breakout kits at each end.
- All fiber termination boxes/enclosures (TDU) shall match the existing used by the district in the current fiber backbone. Current FTU's or Fiber Patch Panels are Leviton rack mount with 12 ports and expandable to 24 ports. The type of FTU may change depending on the ABF fiber entering the building, 6, 12, 18, and 24 strands, 1U or 2U in size. The FTU shall always be mounted at the top of each data rack.

## **Miscellaneous Items**

### Wire Removal

Cables that are abandoned in ceilings, riser systems, and air handling systems have always been a source for fueling smoke and fire. The weight of the cabling has also strained ceiling, raceway, and riser systems. Often times, abandoned cables have been left behind when new cabling is installed. NEC 2002 Article 770.3(B) for optical fiber and Article 800.52(B) for communications cabling states that all accessible abandoned cable, unless marked for future use, must be removed.

The building owner is financially responsible for removing old abandoned cabling. Information Services is available to help coordinate this effort.

### Asbestos Abatement

The building owner is responsible for asbestos abatement. Information Services is available to help coordinate this effort.